

DrizAir 1200 Dehumidifier

(F203, F203-UK, F203-SM, F203-SP, F203-230V, F203-230V UK, F203-GRN, F203-YEI)

Symbol Definition

- * - multiple components to choose from for different models: voltage, size, color, etc
- + - if you order this item, you may need to order additional items marked with same number of +'s in order to upgrade or complete repair

Find#	Part Description	Specifications/Model	Part #	Qty
	Wire	Red 14Ga AWM 105c/600v	02-00099	ft. 3'
	Wire	White 14Ga AWM 105c/600v	02-00101	ft. 2.79
	Wire	Black 14Ga AWM 105c/600v	02-00102	ft. 3.08'
	Wire	Green 14Ga AWM 105c/600v	02-00103	ft. 2'
	Connector	Qc .250 Fem Fully Insul 16/14 Ga	02-00135	ea. 16
67	Terminal Block	Gp 6 x 6 x 8 x 4 Qc	02-00157	ea. 1
86	Capacitor	35 MFD 250v 1.75 Dia Rd w/bracket (115v)	02-00188	ea. 1
87	Capacitor	20 MFD 370v 1.75 Dia Rd w/ bracket (230v)	02-00217	ea. 1
53	Strain Relief	Snap .360 Dia Blk <i>(Use 02-00499 DOM B4 10/20/99)</i>	02-00218	ea. 1
53	Strain Relief	Snap Dia Blk <i>(Use 02-00218 DOM after 10/20/99)</i>	02-00499	ea. 1
	Connector	Ring #10 Insul 16/14 Ga	02-00516	ea. 3
	Flag Term Compr	14-16 .250 (amp) 4000	02-00769	ea. 3
15	Washer	1/4" Rivet .26 ID x .50 OD x .06 Zp	03-00001	ea. 8
	Cable Tie	Nylon 4"	03-00012	ea. 1
106	Cable Tie	Nylon 4"	03-00012	ea. 10
74	Nut	#8-32 Nyloc Zp	03-00015	ea. 2
10	Rivet	1/4 x 1/2 Stl/Stl Zp	03-00022	ea. 4
84	Screw	#8 x 1/2" Pan Hd Phil Sms Zp	03-00023	ea. 14
18	Cap	Cap- Plastic Blk 1.125 Dia	03-00027	ea. 1
17	Nut	#10-24 w/star washer Zp	03-00038	ea. 8
58	Bushing	.39 ID x .562 x .406 Split Nylon Blk	03-00050	ea. 1
107	Screw	#10 x 3/8" Ab Slr Hwh Zp Blk	03-00079	ea. 2
118	Washer	.375 ID x .875 OD x .07 Zp	03-00086	ea. 3
69	Screw	#8 x 3/4" Ab Phil Hd Zp	03-00095	ea. 2
68	Screw	1/4-20 x 3/8 Hwh w/ Nyloc Zp	03-00105	ea. 14
	Insert	1/4-20 x .50 x .50 Hh Al (Cover)	03-00106	ea. 4
	Insert	1/4-20 x .50 x .50 Hh Al (Rear Panel)	03-00106	ea. 8
8	Nut	5/8-11 Nyloc Thin Zp	03-00113	ea. 2
9	Washer	5/8 AN .63 ID x 1.187 OD x .06 SS	03-00114	ea. 4
	Nut	3/8 Npt Insert Brass (Rear)	03-00115	ea. 1
81	Screw	1/4-20 x 1.75 Ser Hwh Zp	03-00118	ea. 2
80	Gasket	1/2 x 1/2 Polyurethane Psa (55") (Rev F)	03-00121	ft. 4.58'
43	Gasket	1/2 x 1/2 Polyurethane Psa (30")	03-00121	ft. 2.5'
42	Gasket	1/2 x 1/2 Polyurethane Psa (13")	03-00121	ft. 1.084'
35	Gasket	1/2 x 1/2 Polyurethane Psa (4")	03-00121	ft. .34'
30	Gasket	1/2 x 1/2 Polyurethane Psa (13")	03-00121	ft. 1.08'
19	Gasket	1/2 x 1/2 Polyurethane Psa (32")	03-00121	ft. 2.67'
6	Bushing	.671 ID x .875 x .41 Split Nylon Black	03-00126	ea. 2
14	Rivet	1/4 x 3/4 Stl/Stl Zp	03-00135	ea. 2
71	Mounting Pad	Nylon Tie 3/4 x 4 Way Psa	03-00141	ea. 1
116	Grommet	.38 ID x 1.25 OD x .63 Rubber Blk (230v)	03-00177	ea. 3
117	Washer	Shoulder .515 ID x 1.125 OD x .093 Nylon	03-00178	ea. 3
120	Rivet	1/4 x 1/4 Stl/Stl 8-4	03-00208	ea. 6
1	Rivet	Stl/Stl SB6-4 Z1 x Black	03-00432	ea. 16

Find#	Part Description	Specifications/Model	Part #	Qty
61	Clamp	3/8 ID Hose Green	03-00471	ea. 1
13	Washer	3/8 Uss .438 ID x 1.00OD x .083 Zp	03-00506	ea. 3
95	Push Mount	Heyco (Rev B)	03-00771	ea. 1
36	Cable Tie	11" Nylon	03-00813	ea. 2
77	Rivet	1/8 x 1/8 Al/Al AAP 42	03-00901	ea. 2
79	Screw	#8-32 x 1/4 Hwh Class 2 TF	03-00962A	ea. 4
88	Washer	Rivet 5/32"	03-01333	ea. 2
89	Rivet	5/32 x 1/2 Al/Al Zp Blk Anod	03-01367	ea. 2
12	Bolt	Shoulder 5/18-18 x 3/4	03-01427	ea. 3
16	Screw	10-24 x 1/2" Slot Hwh Zp	03-01429	ea. 2
	Clamp	Hose clamp 1/2 ID (for 13-00083 & 08-01519)	03-01481	ea. 2
48,49	Rivet	5/32 X 1/4 Tri Fold Al/Al Black	03-01487	ea. 3
50	Plate	Strain Relief w/ Pc Winkle Blk	04-00052-01	ea. 1
	Foam Wrap	6" x 6" Perf White Psa .125 Thick	06-00035	ea. 3
	Box	20.63 x 19.0 x 28.75 323DW HH48 Rsc Pln	06-00083	ea. 1
	Foam	18.0 x 18.0 x 1.0 Eps 1lb	06-00084	ea. 1
	Foam	2.13 x 2.13 x 28.0 Eps 1lb	06-00085	ea. 2
	Capsule	1 x 1-1/2 Recloseable Caps-Gel (for paste)	06-00105	ea. 1
64	Label	Model Serial CE Dehus, 230v (w/serial num)	07-00162	ea. 1
63	Label	Model Serial UL/CUL, 115v (w/serial num)	07-00165	ea. 1
	Manual	Owners 230v CE Dehu	07-00212	ea. 1
47	Label	Warning Turbos (Indoors)	07-00259	ea. 1
	Insert	Declaration of Conformity, 230v	07-00289	ea. 1
82	Label	Product	07-00302	ea. 1
92	Label	Product DZ1200 SM (F203-SM)	07-00312	ea. 1
93	Label	Product DZ1200 SP (F203-SP)	07-00313	ea. 1
	Instructions	Pump Testing / MicroSwitch Replacement	07-00397	ea. 1
59	Label	Caution y/b Dehumid	07-01432	ea. 1
	Manual	Owners (115v units)	07-01486	ea. 1
25	Valve	Solenoid, Bypass 1.9mm	08-00108	ea. 1
	Tubing	3/16 OD x 030 w/ Soft AC/R	08-00153	ft. 1.5'
57	Duct Ring	6" Dia Abs Blk	08-00157	ea. 1
38	Pump	115v, Centrifugal 80 Gph 5 Ft Cord	08-00177	ea. 1
39	Pump	230v, Centrifugal 80 Gph 5ft Cord (-230v UK)	08-00197	ea. 1
54	Power Cord Assy *	3 X 1.5MM CEE7/7 25 ft (230V EU)	08-00200	ea. 1
55	Power Cord Assy *	3 x 1.5mm BS1363 25' (230v UK)	08-00201	ea. 1
46	Cover	Polyethylene Fisher Blue, Front	08-00205S	ea. 1
33	Cover	Polyethylene Teal Green, Front (-SM)	08-00205-01S	ea. 1
94	Cover	Poly Turf Green , front (-SP, -GRN)	08-00205-02S	ea. 1
119	Cover	Poly Bright Yellow (F203-YEL)	08-00205-03S	ea. 1
70	Rear Panel	Polyethylene Flint Grey	08-00206S	ea. 1
40	Base	Galvanized Steel	08-00207	ea. 1
3	Bulkhead	Galvanized Steel	08-00208	ea. 1
34	Shield	Pump Galvanized Steel	08-00209	ea. 1
85	Shroud	Filter Pc Wrinkle Blk	08-00210-01	ea. 1
20	Coil Assy	Evaporator/Condenser	08-00211	ea. 1
11	Axle Assy	5/8 OD x 20.29 Zp Stl	08-00212-01	ea. 1
66	Bracket	Handle Galvanized Steel	08-00213	ea. 1
56	Hose Wrap	.250 Wire Pc Wr Blk	08-00214-01	ea. 2
2	Coil Frame	Coil Galvanized Steel	08-00215	ea. 1
73	Blower Assy	230v/50Hz, Centrifugal 1350RPM 1 spd	08-00217	ea. 1
90	Electrical Box	Galvanized Steel	08-00218	ea. 1
78	Panel	Lower Electrical Box Galvized Steel	08-00219	ea. 1
91	Panel	Upper Electrical Box Galvanized Steel	08-00220	ea. 1
75	Shield	Motor Galvanized Steel	08-00221	ea. 1
28	Refrigeration Lines	115v/230v, Set	08-00222S	ea. 1
51	Handle Assy ++	Telescoping	08-00223	ea. 1
	Wire Harness	115v/230v	08-00225S	ea. 1
52	Power Cord Assy	115v, 16/3 SJTW 5-15P 25ft	08-00226	ea. 1

Find#	Part Description	Specifications/Model	Part #	Qty
5	Compressor * +++	230v, Compressor 6370 BTU	08-00228	ea. 1
109	Solenoid Assy *	115v	08-00231	ea. 1
110	Solenoid Assy *	230v	08-00232	ea. 1
96	Overload * +++	115v, Compressor	08-00235	ea. 1
97	Overload * +++	230v, Compressor	08-00237	ea. 1
98	Nut +++	Terminal Cover Hh	08-00240	ea. 1
99	Washer +++	Gasket 7/32 ID x 9/16 OD Rubber	08-00241	ea. 1
111	Spring +++	1-1/16 OD x 1/2 h	08-00242	ea. 1
112	Gasket +++	Terminal Cvr 2-5/16 x 3-9/16 x .036 Rubber	08-00243	ea. 1
113	Cover +++	Terminal 3-14 x 2-1/8 x 1-5/8 Plastic	08-00244	ea. 1
114	Grommet +++	.375 ID x 1.50 OD Rubber Black	08-00247	ea. 3
72	Blower Assy	115v/60Hz, Centrifugal 1550RPM 1 spd	08-00257	ea. 1
76	Control Panel	115/230v (Use w/ 08-00260) S/N >8818	08-00259	ea. 1
115	Sensor Cable Assy	Temp Defrost Dehus (Use w/ 08-00259)	08-00260	ea. 1
	Control Plate Assy	(Part of 08-00259 & in kit S253)	08-00263	ea. 1
	Refrigerant	R-417A, 230v units (\$25.00 Flat Fee)	08-00265	oz. 18
	Microswitch +	115v/230v (for pump)	08-00298	ea. 1
	Screw +	Microswitch, Centrifugal pump	08-00299	ea. 2
	Nut +	Microswitch, Centrifugal pump	08-00300	ea. 2
	Washer, lock +	Microswitch, Centrifugal pump	08-00301	ea. 4
4	Compressor * +++	115v, 6745 BTU High Eff (As of 11/5/01)	08-00304	ea. 1
	Refrigerant	R-22, 115v units (\$25.00 Flat Fee)	08-00755	oz. 16
105	Insulation	Cork Tape 2" (6")	08-00784	ft. 0.5'
104	Insulation	Cork Tape 2" (1")	08-00784	ft. .084'
103	Insulation	Cork Tape 2" (6")	08-00784	ft. 0.5'
102	Insulation	Cork Tape 2" (6")	08-00784	ft. 0.5'
101	Insulation	Cork Tape 2" (3")	08-00784	ft. 0.25'
	Insulation	Pipe 3/8 ID x 3/8 Wall (Refrigeration Lines)	08-00785	ft. 3'
	Filter Dryer	1/2 Ton	08-01460	ea. 1
	Drip Tray	ABS Blk 1200	08-01518	ea. 1
	Handle	Fixed PC WR Blk DZ 1200	08-01524-01	ea. 1
	Power Cord Assy *	3 X 1.5MM H05RN BS 4343 25FT DZ1200 UH	08-01526	ea. 1
108	Tape	1" Blk Med Psa Resil (1.5")	13-00003	ft. 0.125'
7	Wheel	12 x 2 x 5/8 Bore Grey w/Dustcaps	13-00053	ea. 2
37	Tubing	3/8 x 5/8 OD Braided Pvc (35")	13-00083	ft. 2.92'
	Tool - F203 Handle ++	Handle - Installation and Removal	13-00151	ea. 1
	Stick	Paste Applicator for external repairs	13-00158	ea. 1
62	Tubing	1/4" ID x 3/8" OD Vinyl, pump out	15-00195	ft. 40'
31	Tubing, Inlet	1/2" ID x 3/4" OD Clear Vinyl (4.5")	15-01463	ft. .375'
24	Fitting	Tee 1/4 x 1/4 x 1/4 Copper	18-00756	ea. 1
	Tubing	1/4" Copper Soft AC/R	18-00757	ft. 2.58'
	Tubing	3/8" Copper Soft AC/R	18-00758	ft. 2.78'
26	Fitting	Tee 3/8 x 3/8 x 1/4 Copper AC/R	18-00764	ea. 1
27	Valve	Line Service 1/4" Dia Copper	18-00817	ea. 1
41	Fitting	3/8 x 1/4 Reducer	18-01052	ea. 1
32	Fitting	3/8 MPT x 1/2 Hb Nylon	18-01391	ea. 1
	Thermal Paste	Thermal Mastic - 8 oz Tube	50-005	ea. 0.025
	Tool - Blower Wheel	Blower Wheel - #20 Torx Bit T-Handle	S247	ea. 1
	Handle-Crossbar Assy	Includes crossbar, foam, rivets	S249	ea. 1
	Control Panel Kit	Programmable Control Panel Upgrade	S253	ea. 1
	Microswitch Kit +	incl. screws, nuts, washers	S262	ea. 1
	Refrigeration Lines	Suction-115v/230v DZ1200 Modification	S264	ea. 1
	Handle Kit	DrizAir 1200 Rigid handle upgrade kit	S375	ea. 1

DrizAir 1200 Pictorial Drawing

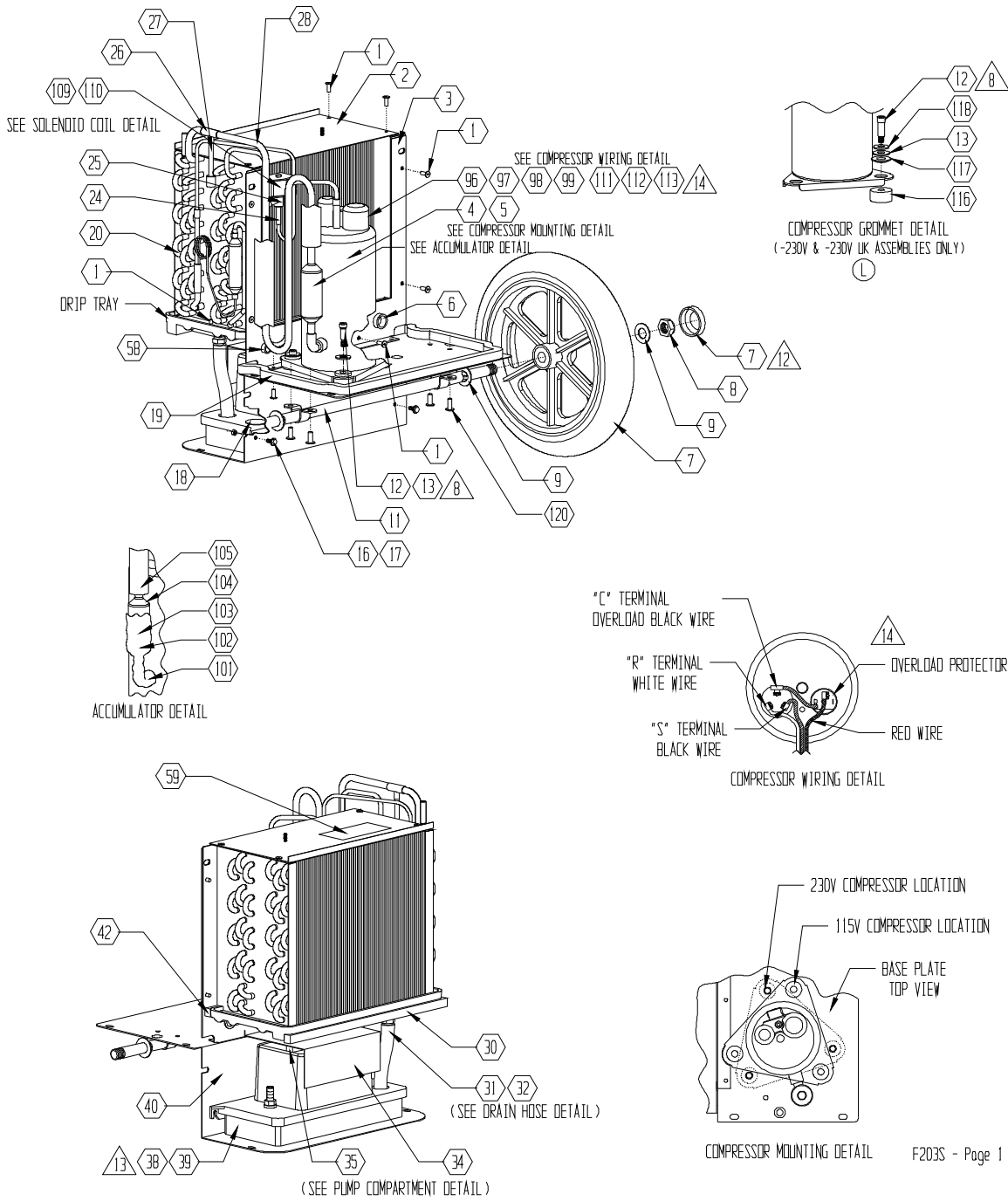

DrizAir 1200 Pictorial Drawing

F203S - Page 2

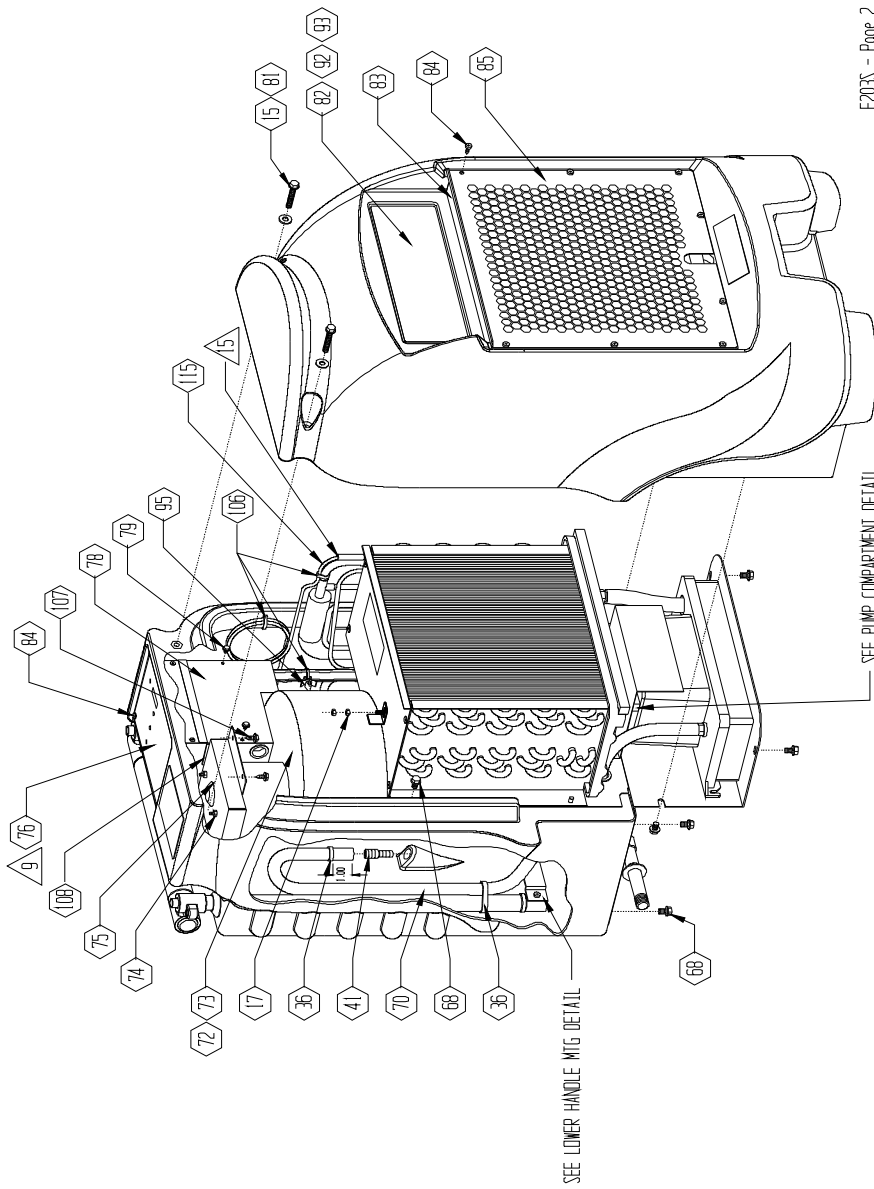

SEE LOWER HANDLE MFG DETAIL

SEE PUMP COMPARTMENT DETAIL

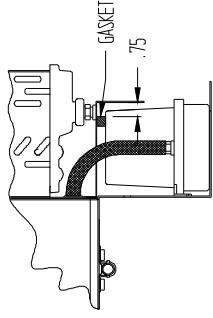

(P) PUMP COMPARTMENT DETAIL

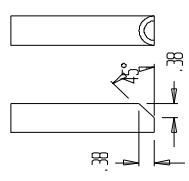

(E) DRAIN HOSE DETAIL

DrizAir 1200 Pictorial Drawing

F203S - Page 3

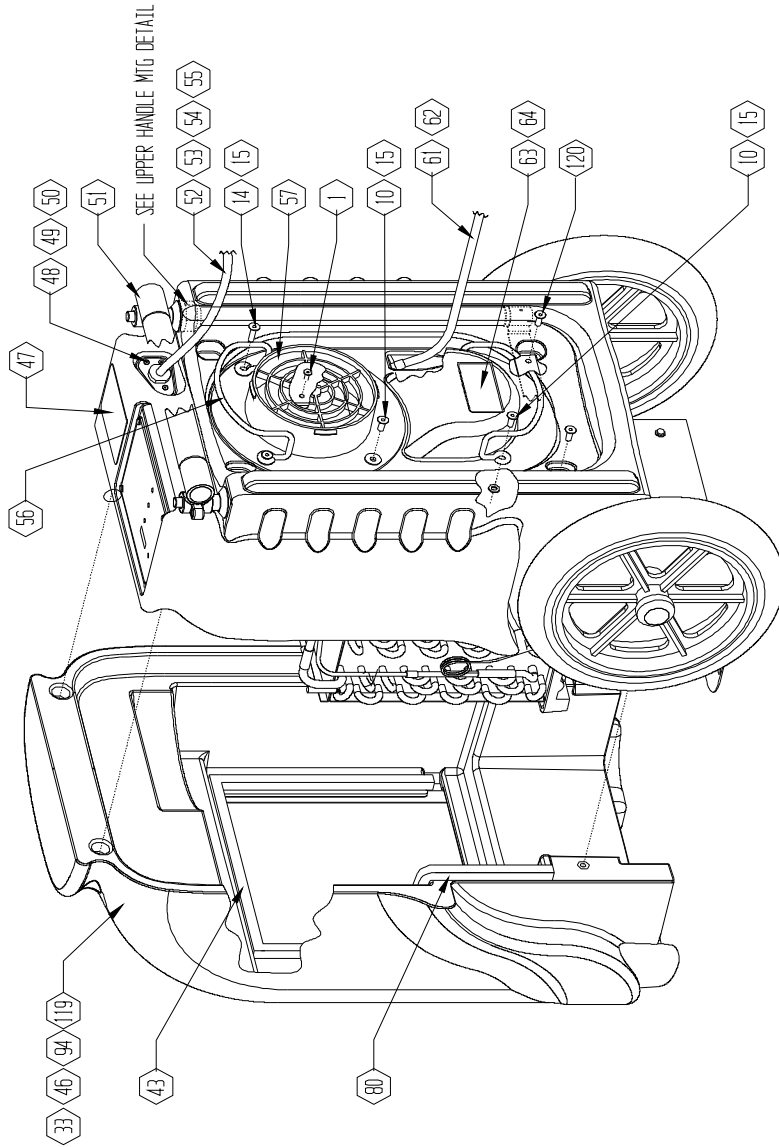

SEE UPPER HANDLE MTG DETAIL

